

**SANT LONGOWAL INSTITUTE OF ENGINEERING AND TECHNOLOGY  
LONGOWAL-148106, SANGRUR, PUNJAB**

**SLIET MECHANICAL ENGINEERING SOCIETY (S.M.E.S)**

S.no	Activities	Date
1	<b>Technical and Aptitude Quiz</b>	24th Feb. 2023
2	<b>Fundamentals of AutoCAD and its applications</b>	08th-12th May. 2023

- Title of Programme **Technical and Aptitude Quiz**

Organized by: - **SLIET MECHANICAL ENGINEERING SOCIETY (S.M.E.S)**

Venue: - **Mechanical Block(LM:-01-09)**

Target participants: - **ICD & DEGREE**

No. of participants attended the program: - **142**

Objectives of the programme: - **To enhance the engineering knowledge of students**

Photographs of the event







REPORT ON QUIZ ORGANIZED BY SLIET MECHANICAL ENGINEERING SOCIETY (SMES) ON 24<sup>TH</sup> FEBRUARY 2023

On 24<sup>th</sup> February 2023, the SLIET Mechanical Engineering Society (SMES) organized a quiz competition at Sant Longowal Institute of Engineering and Technology. The event was open to all students from different branches of the institute, and a total of 142 students participated in the quiz. The participants were divided into two categories: ICD (Diploma) and UG (Undergraduate).

The quiz started at 5:00 pm and lasted for 25 minutes, ending at 5:25 pm. The questions were designed to test the participants' aptitude and technical knowledge. The quiz covered various topics related to mechanical engineering and included questions on both theoretical concepts and practical applications.

All participants were required to pay an entry fee of 10 rupees to participate in the quiz. The entry fee was used to meet the expenses associated with organizing the event, printing notice and refreshment etc.

Total amount received:-RS1420



In the ICD category, the winners were as follows:

1. Sudhir Kumar – Registration Number: 2010564
2. Sudhanshu Ranjan – Registration Number: 2010575

In the UG category, the winners were as follows:

1. Prince Raj – Registration Number: 2236123
2. Prashant Mangalam – Registration Number: 2236120

These winners demonstrated exceptional aptitude and technical knowledge in their respective categories. Their achievements reflect their dedication to their studies and their passion for mechanical engineering.

The quiz competition organized by the SLIET Mechanical Engineering Society (SMES) was a resounding success. It provided an excellent platform for students to showcase their knowledge and skills in aptitude and technical aspects of mechanical engineering. The event fostered healthy competition among participants and encouraged a deeper understanding of the subject.

We extend our congratulations to all the winners and participants for their active involvement in the quiz competition. We would also like to express our appreciation to the organizers and volunteers of SMES for their efforts in making this event a memorable one.

5. 1 point

How many times the hands of a clock coincide in a day?

Mark only one oval.

- 24  
 22  
 23  
 21

6. 1 point

Find the H.C.F, if the numbers are in the ratio of 4 : 5 : 6 and their L.C.M. is 2400

Mark only one oval.

- 35  
 20  
 40  
 67

7. 1 point

When the door of a refrigerator is kept open then the room temperature starts

Mark only one oval.

- Cool down.  
 Hot up.  
 first cool down then hot up.  
 neither cool down nor hot up.

8. 1 point

Find the missing number in the series? 4, 18, ?, 100, 180, 294, 448

Mark only one oval.

- 48  
 50  
 58  
 60

Which Indian film wins the Best Foreign Language film award in the 28<sup>th</sup> Critics' awards?

Mark only one oval.

- RRR  
 K.G.F  
 KANTARA  
 PONNIYIN SELVAN

10. 1 point

Which country's President was the chief Guest at the Republic Day's parade this year 2023?

Mark only one oval.

- ALGERIA  
 EGYPT  
 JORDAN  
 QATAR

11. 1 point

DESERT : MIRAGE :: OCEAN : ?

Mark only one oval.

- El-Nino  
 whale  
 Blizzard  
 Hail

12. 1 point

A and B together can complete a piece of work in 72 days, B and C together in 120days A and C together in 90days. A,Band C together can complete the work in?

Mark only one oval.

- 35days  
 40days  
 48days  
 60days

13. 1 point

Light from Sun reaches Earth in approximately.

Mark only one oval.

- 3 minute  
 8minute  
 10minute  
 12minute

14. 1 point

Who is the first person to define speed?

Mark only one oval.

- Galileo  
 Newton  
 Kepler  
 Ptolemy

15. 1 point

The speed of sound in air depends on

Mark only one oval.

- Frequency
- Temperature
- Wavelength
- None of the above

16. 1 point

"Intelligence quotient" was developed by

Mark only one oval.

- Wundt
- Terman
- Freud
- william stern

17. 1 point

If Satish increases his Speed from 12 km/hr to 15 km/hr while coming from Office to home, he reaches home one hour early. Determine the distance between his home and the office.

Mark only one oval.

- 40km
- 50km
- 60km
- 70km

18. 1 point

A man rows a boat at 8 km upstream in 2 hours and 2 km downstream in 40 minutes. How long will he take to reach 7 km in still water?

Mark only one oval.

- 2hr
- 3 hr
- 2hr 15 min
- 6hr

19. 1 point

Who is known as father of internet?

Mark only one oval.

- Alan Perlis
- Jean E. Sammet
- Vint Sirf
- Steve lawrence



Title of Programme **Fundamentals of AutoCAD and its applications**

Organized by: - **SLIET MECHANICAL ENGINEERING SOCIETY (S.M.E.S)**

Venue: - **Mechanical Block(CCF LAB)**

Target participants: - **ICD & DEGREE**

No. of participants attended the program: **51**

Photographs of the event





# SANT LONGOWAL INSTITUTE OF ENGINEERING AND TECHNOLOGY

LONGOWAL, SANGRUR, PUNJAB 148106



## DEPARTMENT OF MECHANICAL ENGINEERING

One-week training workshop  
On

## Fundamentals of AutoCAD and its applications

ORGANISED BY \_\_\_\_\_

SLIET MECHANICAL ENGINEERING SOCIETY

COORDINATED BY \_\_\_\_\_

Dr. Mohd Majid AP,ME

Dr. Sunil kumar AP,ME

TEAM MEMBERS \_\_\_\_\_

Kishan Kashyap

Ashutosh Raj

Pratik Kamal

Abhishek Kumar

Askand Prabhu

## CONTENT LIST-

INTRODUCTION

PROPOSAL LETTER

ANNEXURE

DAILY REPORT

ATTENDANCE

PARTICIPANT FEEDBACK

# INTRODUCTION

AutoCAD is a CAD software for creating 2D and 3D designs and drawings, widely used in industries like architecture, engineering, construction, and manufacturing. Its comprehensive set of tools and features, user-friendly interface, and ability to handle large amounts of data make it a versatile and popular choice for professionals on multiple platforms.

## PURPOSE

SMES has organized workshop on the fundamentals of AutoCAD equip participants with essential skills and knowledge in computer-aided design (CAD) using AutoCAD software.

Proficiency in AutoCAD is highly sought after by employers in various industries. By participating in this training, individuals can enhance their employability and increase their chances of securing jobs or internships in relevant fields.

Regular updates introduce new features, performance enhancements, and compatibility improvements, ensuring that users have access to the latest tools and technologies in design and drafting.



# DAILY REPORT

## DAY 1

### INTRODUCTION ON AutoCAD

AutoCAD is a widely used computer-aided design (CAD) software developed by Autodesk. It allows users to create, modify, and document 2D and 3D designs with precision. AutoCAD finds applications in various industries, such as architecture, engineering and manufacturing.

### USES AND FUTURE SCOPE

AutoCAD is a widely used software for design and drafting. Learning AutoCAD offers career opportunities in architecture, engineering, construction, and manufacturing. It allows users to create accurate drawings, 3D models, and construction documentation. Proficiency in AutoCAD enhances design skills and productivity in various industries.

### DEMAND IN INDUSTRY

AutoCad has a major advantage over BIM specific software. The analogy that I use is that AutoCad is basically a giant drawing pad and Revit is lego. AutoCad is so versatile there is nothing that you cannot draw with it, it interacts well with image files and software like Word

## DAY 2

### ABOUT AutoCAD INTERFACE

1. Ribbon: A toolbar at the top of the AutoCAD interface that provides access to various commands and tools.
2. Command Line: A text-based interface at the bottom of the screen where users can enter commands and receive prompts and feedback.
3. Tool Palettes: Customizable panels containing frequently used tools, blocks, and symbols for quick access.
4. Drawing Area: The main workspace where users create and modify designs.
5. Viewports: Display multiple views of a design within a single drawing file.
6. Layers: Organize and manage different components of a drawing, controlling visibility and properties.
7. Drawing Tools: Tools for creating precise shapes and geometry within the drawing area.

## 8. Modifying Tools: Tools for manipulating and editing objects, such as move, copy, and rotate.

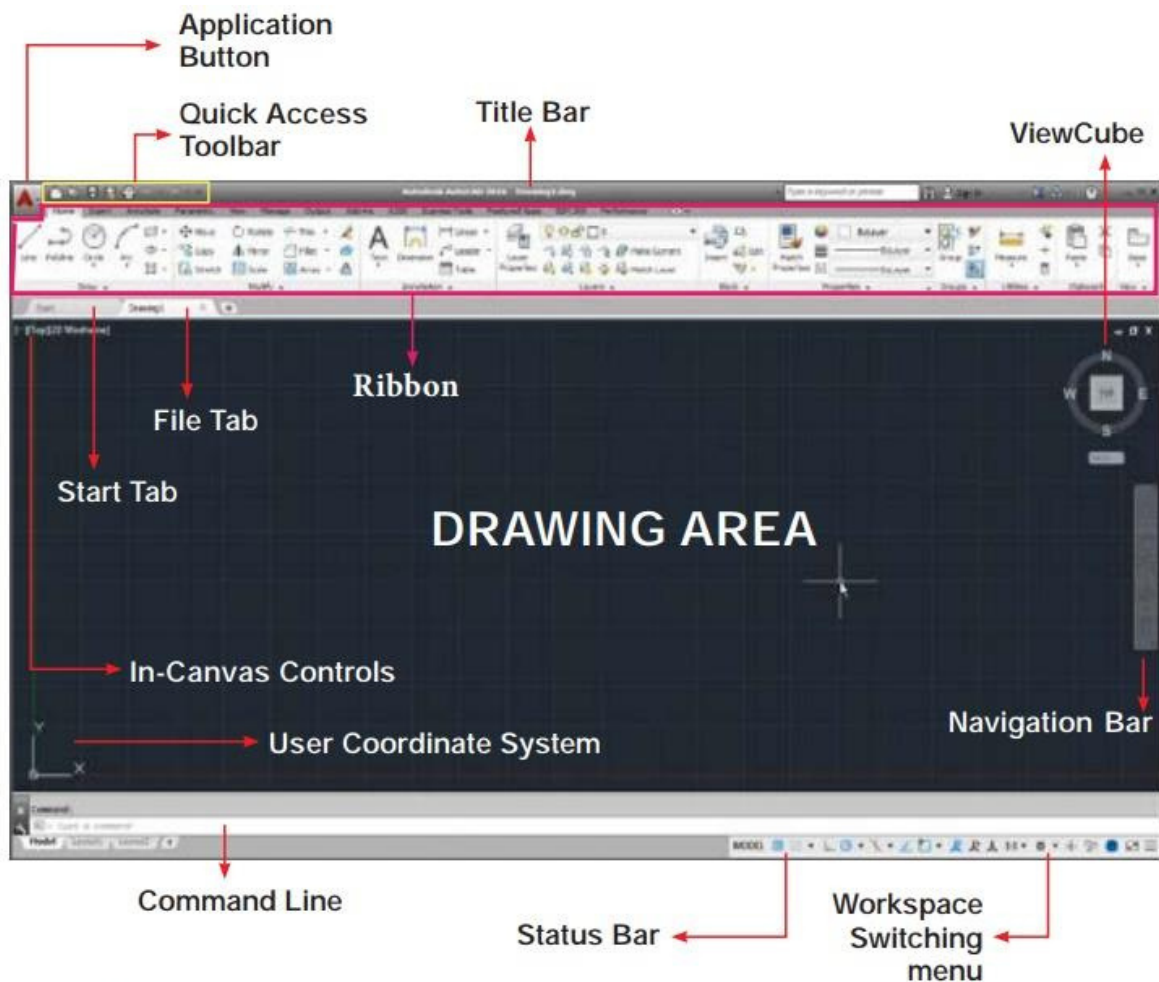
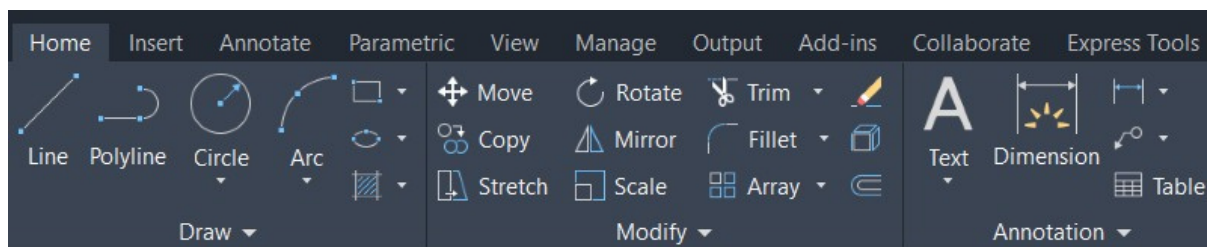

Fig. 6.5 AutoCAD 2016 screen components in AutoCAD Drafting & Annotation workspace

## DAY 3

### ABOUT AutoCAD TOOLS

1. Line: Creates straight lines.
2. Circle: Draws circles.
3. Arc: Creates arcs.
4. Rectangle: Draws rectangles.
5. Polyline: Creates continuous shapes.
6. Hatch: Fills closed areas.
7. Text: Inserts text.
8. Dimension: Adds dimensions.
9. Block: Creates reusable objects.
10. Layer: Manages layers.
11. Modify Edits objects.
12. Mirror: Creates mirrored copies.
13. Offset: Creates parallel copies.
14. Fillet: Rounds corners.
15. Chamfer: Bevels edges.



DAY 4

PRACTISE SESSION ON AutoCAD

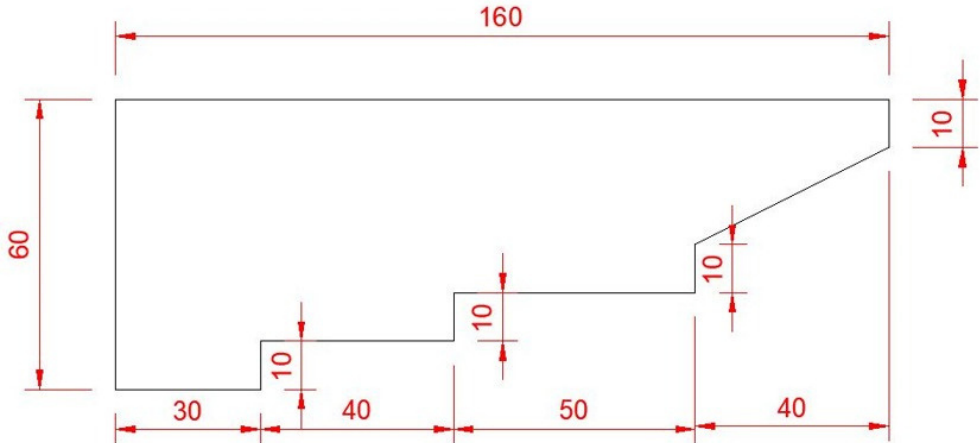
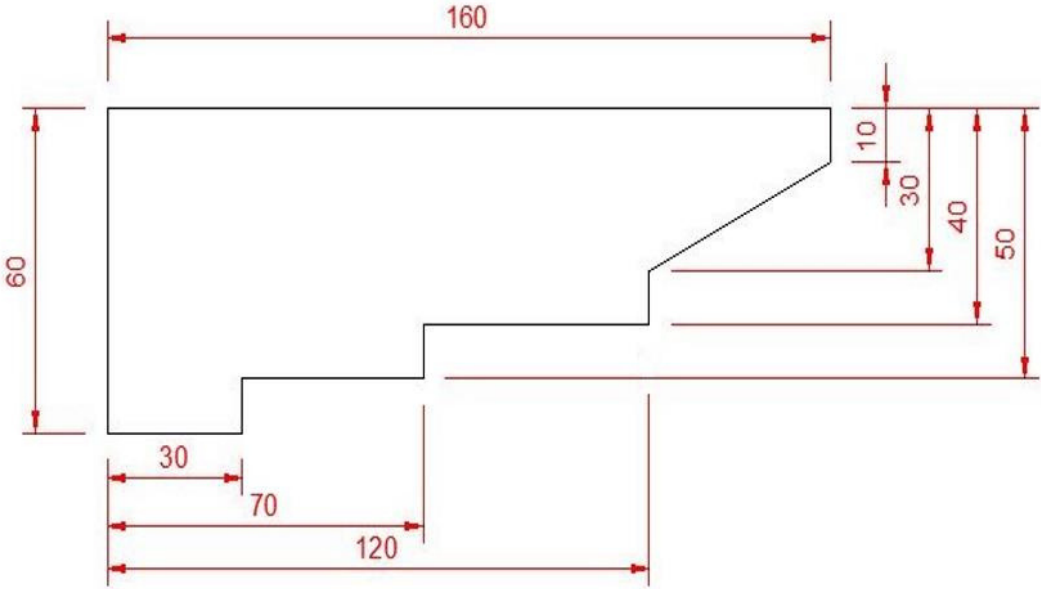



# DAY 5

## PRACTISE SESSION ON AutoCAD

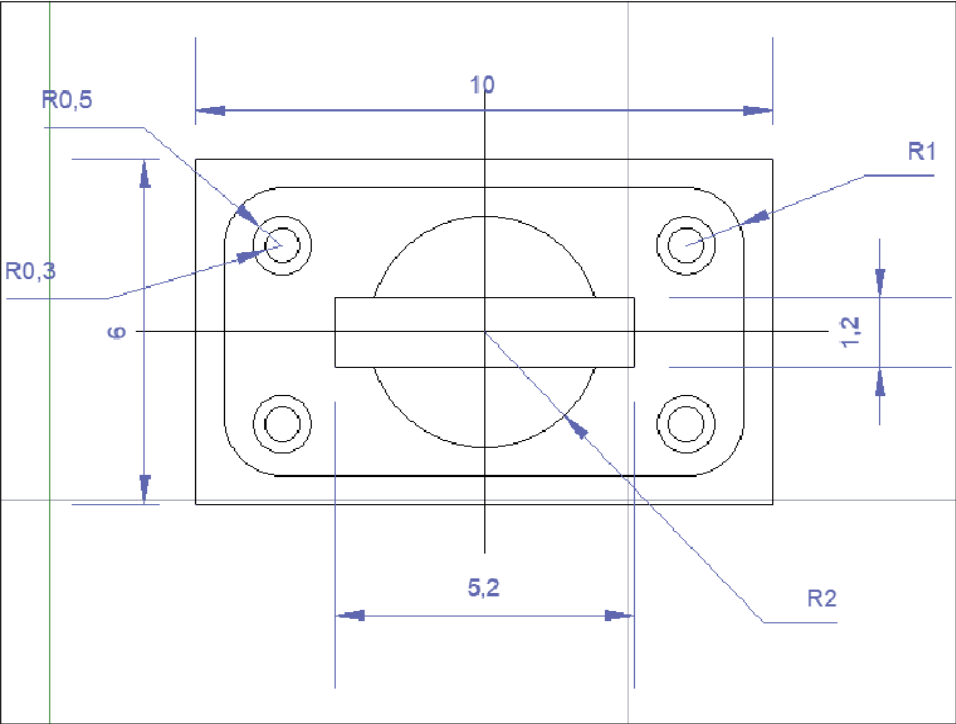
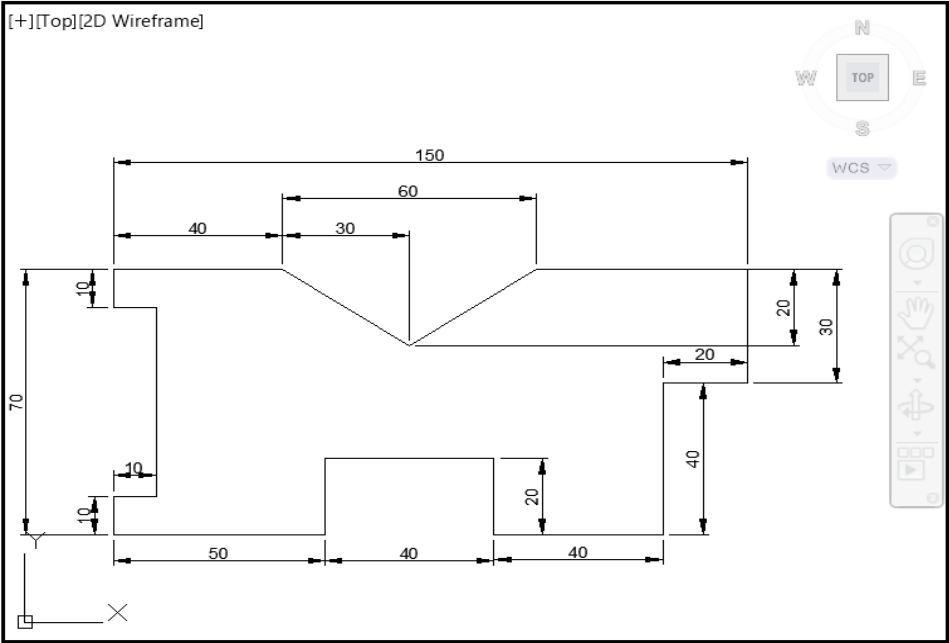

# Feedback of students on day1

Timestamp	Feedback for today's Aut	Suggestions for improv	Name	Email	Registration Number
5/8/2023 20:18:42	Very Good (4)		Abhishek	keshriabhishek570@gmail	
5/8/2023 20:27:02	Excellent (5)		Tushar kumar	2110928@sliet.ac.in	2110928
5/8/2023 20:27:13	Excellent (5)		Aditya Raj	araj87314@gmail.com	2110940
5/8/2023 20:27:14	Excellent (5)	No suggestion ,all good	Raja kumar	rajaiitm2003@gmail.com	2010418
5/8/2023 20:28:42	Good (3)	Teach low level so to und	Saket kumar	2110912@sliet.ac.in	2110912
5/8/2023 20:29:09	Excellent (5)	Good	Anand Kumar singh	2010469@sliet.ac.in	2010469
5/8/2023 20:31:39	Excellent (5)	Try to cover all portion of	Ayush kumar thakur	2010657@sliet.ac.in	2010657
5/8/2023 20:31:48	Good (3)		Anup Yadav	2246020@sliet.ac.in	2246020
5/8/2023 20:33:50	Excellent (5)	All PCs are not working pi	Gaurav kumar	2110723@sliet.ac.in	2110723
5/8/2023 20:34:01	Excellent (5)		Birendra Kumar	2236131@sliet.ac.in	2236131
5/8/2023 20:34:21	Excellent (5)		Ritesh Tomar	2236118@sliet.ac.in	GME -2236118
5/8/2023 20:34:21	Very Good (4)	First day was good. Try to complete all levels	SUMIT RANJAN JHA	2010671@sliet.ac.in	2010671
5/8/2023 20:34:31	Excellent (5)	Mouse is not there at my	Alok kumar	2110713@sliet.ac.in	2110713
5/8/2023 20:35:10	Very Good (4)	Keyboard was missing	Arjun Kumar	2110710@sliet.ac.in	2110710
5/8/2023 20:35:57	Excellent (5)		Chanchal kumar	2110924@sliet.ac.in	2110924
5/8/2023 20:37:02	Excellent (5)	very good suggestion	bipul Kumar Shahi	bipulkum8409949775@gr	2130760
5/8/2023 20:38:39	Excellent (5)		Nitish kumar	2110922@sliet.ac.in	2110922 - CBM
5/8/2023 20:38:42	Very Good (4)		Adarsh Thakur	thakuradarsh926@gmail.	Adarsh Thakur
5/8/2023 20:39:32	Good (3)	Teacher can be better	Mujahid Hussain	mujahidhussainqwertyuio	2241061
5/8/2023 20:47:09	Good (3)	No....	YOGESH KUMAR	2110926@sliet.ac.in	2110926
5/8/2023 20:47:12	Very Good (4)	No	Raman Kumar	2110817@sliet.ac.in	2110817
5/8/2023 20:48:36	Excellent (5)	Improvement in computer	Dikshit kumar	2110921@sliet.ac.in	2110921
5/8/2023 21:06:09	Excellent (5)		Shashi Kumar	2140014@sliet.ac.in	2140014
5/8/2023 21:32:36	Very Good (4)		Gaurav Kumar Puri	2110401@sliet.ac.in	2110401
5/8/2023 21:35:40	Excellent (5)		Raina singh	2110714@sliet.ac.in	2110714
5/8/2023 21:44:00	Excellent (5)	Nothing	Vanshika	2010067@sliet.ac.in	2010067
5/8/2023 22:00:04	Excellent (5)		Parkash kumar	2110701@sliet.ac.in	2110701
5/8/2023 22:12:43	Excellent (5)	I think today's session wa	Vikas kumar yadav	2140054@sliet.ac.in	2140054
5/9/2023 1:24:32	Very Good (4)		Vipin kumar	2140011@sliet.ac.in	2140011
5/9/2023 10:45:39	Good (3)		Ayush Raj	2110371@sliet.ac.in	2110371
5/9/2023 14:48:16	Excellent (5)		Pragti chauhan	pragticheuhan458@gmail	2236097
5/9/2023 14:58:52	Excellent (5)		Aditya Raushan	2110929@sliet.ac.in	2110929
5/9/2023 15:08:11	Excellent (5)		Pushkar tiwari	2110703@sliet.ac.in	2110703
5/9/2023 15:13:40	Excellent (5)	Nothing	Satyam Suman	2110935@sliet.ac.in	2110935
5/9/2023 15:30:19	Good (3)		Arafat Ghani Yousuf	2140003@sliet.ac.in	2140003
5/9/2023 16:08:15	Excellent (5)		Shubham kumar	2236133@sliet.ac.in	2236133
5/9/2023 16:28:33	Excellent (5)	Nothing	Aman Verma	2140008@sliet.ac.in	2140008
5/9/2023 16:28:54	Excellent (5)	All good	Kamal Singh	2140012@sliet.ac.in	2140012
5/9/2023 17:45:54	Very Good (4)		Tripti Anand	triptianand1709@gmail.cc	2236142
5/9/2023 17:51:06	Good (3)	Nothing	Anya kumari	2236079@sliet.ac.in	2236079
5/9/2023 17:53:10	Excellent (5)	Nothing	Vaibhav Anand	2236088@sliet.ac.in	2236088
5/9/2023 17:53:32	Excellent (5)		Saransh Sharma	2234105@sliet.ac.in	2234105
5/9/2023 19:16:08	Excellent (5)	NA	Mohammad Nadeem mar	2140382@sliet.ac.in	2140382
5/9/2023 22:12:30	Excellent (5)		MD AAMIR HUSSAIN	mdaamirhussain721@gm	2010018
5/9/2023 22:14:48	Very Good (4)	Nothing	Saloni kumari	2236139@sliet.ac.in	2236139
5/10/2023 9:00:43	Very Good (4)		Sonu kumar	2140415@sliet.ac.in	2140415

# Feedback of students on day2

1	Timestamp	Name	Email	Registration Number	Feedback for 3rd Day A	Suggestions for improvement
2	5/10/2023 19:09:45	Saket kumar	2110912@sliet.ac.in	2110912	Good (3)	Nothing
3	5/10/2023 19:09:53	Raja Kumar	rajaiitm2003@gmail.com	2010418	Excellent (5)	
4	5/10/2023 19:09:55	Parkash kumar	2110701@sliet.ac.in	2110701	Very Good (4)	
5	5/10/2023 19:09:59	Pushkar tiwari	2110703@sliet.ac.in	2110703	Good (3)	
6	5/10/2023 19:10:10	Shubham kumar	2236133@sliet.ac.in	2236133	Excellent (5)	
7	5/10/2023 19:12:03	Anya kumari	2236079@sliet.ac.in	2236079	Very Good (4)	Nothing
8	5/10/2023 19:12:35	Chanchal kumar	2110924@sliet.ac.in	2110924	Excellent (5)	
9	5/10/2023 19:13:22	Arjun Kumar	2110710@sliet.ac.in	2110710	Very Good (4)	Keyboard was Missing
10	5/10/2023 19:13:31	Alok Kumar	2110713@sliet.ac.in	2110713	Very Good (4)	All good
11	5/10/2023 19:13:37	Raina singh	2110714@sliet.ac.in	2110714	Excellent (5)	
12	5/10/2023 19:14:08	Satyam Suman	2110935@sliet.ac.in	2110935	Excellent (5)	Nothing
13	5/10/2023 19:14:21	Vanshika	2010067@sliet.ac.in	2010067	Excellent (5)	No
14	5/10/2023 19:15:24	Sumit Ranjan Jha	2010671@sliet.ac.in	2010671	Good (3)	
15	5/10/2023 19:15:31	YOGESH KUMAR	2110926@sliet.ac.in	2110926	Very Good (4)	No
16	5/10/2023 19:15:57	Ayush kumar thakur	2010657@sliet.ac.in	2010657	Excellent (5)	
17	5/10/2023 19:17:02	Gaurav kumar	2110723@sliet.ac.in	2110723	Excellent (5)	Session was good and knowledge.
18	5/10/2023 19:33:27	Arafat Ghani Yousuf	2140003@sliet.ac.in	2140003	Good (3)	
19	5/10/2023 20:12:18	Raman Kumar	2110817@sliet.ac.in	2110817	Very Good (4)	No
20	5/10/2023 20:31:53	Vikas kumar yadav	2140054@sliet.ac.in	2140054	Excellent (5)	
21	5/10/2023 20:34:23	Nitish kumar	2110922@sliet.ac.in	2110922	Excellent (5)	
22	5/10/2023 20:34:38	Aditya Raj	araj87314@gmail.com	2110490	Excellent (5)	
23	5/10/2023 20:45:42	Dikshit kumar	2110921@sliet.ac.in	2110921	Very Good (4)	
24	5/10/2023 22:12:57	Mohammad Nadeem ma	2140382@sliet.ac.in	2140382	Excellent (5)	NA
25	5/10/2023 23:03:38	Tushar kumar	2110928@sliet.ac.in	2110928	Excellent (5)	
26	5/11/2023 11:55:04	Aditya Raushan	2110929@sliet.ac.in	2110929	Excellent (5)	
27	5/11/2023 11:56:57	Pragti chauhan	pragtichehan458@gmail	2236097	Excellent (5)	
28	5/11/2023 11:57:53	Anup Yadav	2246020@sliet.ac.in	2246020	Very Good (4)	
29	5/11/2023 12:01:16	Adarsh Thakur	thakuradarsh926@gmail.	2234120	Very Good (4)	
30	5/11/2023 12:06:58	Gaurav Kumar Puri	2110401@sliet.ac.in	2110401	Good (3)	
31	5/11/2023 12:11:02	bipul Kumar Shahi	bipulkum8409949775@g	2130760	Excellent (5)	
32	5/11/2023 12:27:18	MD AAMIR HUSSAIN	mdaamirhussain721@gr	2010018	Excellent (5)	
33	5/11/2023 12:33:06	Vinay Kumar	vinaysliet018@gmail.com	2010802	Excellent (5)	No.
34	5/11/2023 12:34:53	Ayush Raj	2110371@sliet.ac.in	2110371	Very Good (4)	
35	5/11/2023 13:10:39	Shashi Kumar	2140014@sliet.ac.in	2140014	Very Good (4)	
36	5/11/2023 14:14:10	Tripti Anan6	triptianand1709@gmail.c	2236142	Very Good (4)	
37	5/11/2023 15:17:18	Saransh Sharma	2234105@sliet.ac.in	2234105	Excellent (5)	
38	5/11/2023 16:40:08	Umang thakur	2010568@sliet.ac.in	2010568	Excellent (5)	Good
39	5/11/2023 17:07:28	Birendra Kumar	birendrakumar4601@gm	2236131	Very Good (4)	
40	5/12/2023 16:28:56	Sonu kumar	2140415@sliet.ac.in	2140415	Excellent (5)	

# Feedback for day3

Timestamp	Name	Email	Registration Number	Feedback for 3rd Day A	Suggestions for improvement
5/10/2023 19:09:45	Saket kumar	2110912@sliet.ac.in	2110912	Good (3)	Nothing
5/10/2023 19:09:53	Raja Kumar	rajaitm2003@gmail.com	2010418	Excellent (5)	
5/10/2023 19:09:55	Parkash kumar	2110701@sliet.ac.in	2110701	Very Good (4)	
5/10/2023 19:09:59	Pushkar tiwari	2110703@sliet.ac.in	2110703	Good (3)	
5/10/2023 19:10:10	Shubham kumar	2236133@sliet.ac.in	2236133	Excellent (5)	
5/10/2023 19:12:03	Anya kumari	2236079@sliet.ac.in	2236079	Very Good (4)	Nothing
5/10/2023 19:12:35	Chanchal kumar	2110924@sliet.ac.in	2110924	Excellent (5)	
5/10/2023 19:13:22	Arjun Kumar	2110710@sliet.ac.in	2110710	Very Good (4)	Keyboard was Missing
5/10/2023 19:13:31	Alok Kumar	2110713@sliet.ac.in	2110713	Very Good (4)	All good
5/10/2023 19:13:37	Raina singh	2110714@sliet.ac.in	2110714	Excellent (5)	
5/10/2023 19:14:08	Satyam Suman	2110935@sliet.ac.in	2110935	Excellent (5)	Nothing
5/10/2023 19:14:21	Vanshika	2010067@sliet.ac.in	2010067	Excellent (5)	No
5/10/2023 19:15:24	Sumit Ranjan Jha	2010671@sliet.ac.in	2010671	Good (3)	
5/10/2023 19:15:31	YOGESH KUMAR	2110926@sliet.ac.in	2110926	Very Good (4)	No
5/10/2023 19:15:57	Ayush kumar thakur	2010657@sliet.ac.in	2010657	Excellent (5)	
5/10/2023 19:17:02	Gaurav kumar	2110723@sliet.ac.in	2110723	Excellent (5)	Session was good and knowledge. No need of improvement
5/10/2023 19:33:27	Arafat Ghani Yousuf	2140003@sliet.ac.in	2140003	Good (3)	
5/10/2023 20:12:18	Raman Kumar	2110817@sliet.ac.in	2110817	Very Good (4)	No
5/10/2023 20:31:53	Vikas kumar yadav	2140054@sliet.ac.in	2140054	Excellent (5)	
5/10/2023 20:34:23	Nitish kumar	2110922@sliet.ac.in	2110922	Excellent (5)	
5/10/2023 20:34:38	Aditya Raj	araj87314@gmail.com	2110490	Excellent (5)	
5/10/2023 20:45:42	Dikshit kumar	2110921@sliet.ac.in	2110921	Very Good (4)	
5/10/2023 22:12:57	Mohammad Nadeem ma	2140382@sliet.ac.in	2140382	Excellent (5)	NA
5/10/2023 23:03:38	Tushar kumar	2110928@sliet.ac.in	2110928	Excellent (5)	
5/11/2023 11:55:04	Aditya Raushan	2110929@sliet.ac.in	2110929	Excellent (5)	
5/11/2023 11:55:57	Pragti chauhan	pragti Chauhan458@gmail.com	2236097	Excellent (5)	
5/11/2023 11:57:53	Anup Yadav	2246020@sliet.ac.in	2246020	Very Good (4)	
5/11/2023 12:01:16	Adarsh Thakur	thakuradarsh926@gmail.com	2234120	Very Good (4)	
5/11/2023 12:08:58	Gaurav Kumar Puri	2110401@sliet.ac.in	2110401	Good (3)	
5/11/2023 12:11:02	bipul Kumar Shahi	bipulkum8409949775@gmail.com	2130780	Excellent (5)	
5/11/2023 12:27:18	MD AAMIR HUSSAIN	mdaamirhussain721@gmail.com	2010018	Excellent (5)	
5/11/2023 12:33:08	Vinay Kumar	vinaysliet018@gmail.com	2010802	Excellent (5)	No.
5/11/2023 12:34:53	Ayush Raj	2110371@sliet.ac.in	2110371	Very Good (4)	
5/11/2023 13:10:39	Shashi Kumar	2140014@sliet.ac.in	2140014	Very Good (4)	
5/11/2023 14:14:10	Tripti Anand	triptianand1709@gmail.com	2236142	Very Good (4)	
5/11/2023 15:17:18	Saransh Sharma	2234105@sliet.ac.in	2234105	Excellent (5)	
5/11/2023 16:40:08	Umang thakur	2010568@sliet.ac.in	2010568	Excellent (5)	Good
5/11/2023 17:07:28	Birendra Kumar	birendrakumar4601@gmail.com	2236131	Very Good (4)	
5/12/2023 16:28:56	Sonu kumar	2140415@sliet.ac.in	2140415	Excellent (5)	

# Feedback for day4

1	Timestamp	Name	Email	Registration Number	Feedback for 4th Day A	Suggestions for improvement
2	5/11/2023 20:00:14	Chanchal kumar	2110924@gmail.com	2110924	Excellent (5)	
3	5/11/2023 20:01:24	Saket kumar	2110912@sliet.ac.in	2110912	Excellent (5)	Nothing
4	5/11/2023 20:01:32	Ayush Raj	2110371@sliet.ac.in	2110371	Very Good (4)	
5	5/11/2023 20:02:13	bipul Kumar Shahi	bipulkum8409949775@g	2130760	Excellent (5)	
6	5/11/2023 20:03:21	Shubham kumar	2236133@sliet.ac.in	2236133	Excellent (5)	
7	5/11/2023 20:04:30	Alok Kumar	2110713@sliet.ac.in	2110713	Very Good (4)	All was very good
8	5/11/2023 20:06:45	Sumit Ranjan Jha	2010671@sliet.ac.in	2010671	Very Good (4)	
9	5/11/2023 20:06:57	Aditya Raj	araj87314@gmail.com	2110940	Excellent (5)	
10	5/11/2023 20:09:00	AYUSH KUMAR THAKUR	2010657@sliet.ac.in	2010657	Excellent (5)	
11	5/11/2023 20:10:10	Adarsh Thakur	thakuradarsh926@gmail.	2234120	Very Good (4)	
12	5/11/2023 20:15:14	Mohammad Nadeem ma	2140382@sliet.ac.in	2140382	Excellent (5)	NA
13	5/11/2023 20:17:01	Dikshit kumar	2110921@sliet.ac.in	2110921	Very Good (4)	
14	5/11/2023 20:17:26	Pragti chauhan	pragtichauhan458@gmai	2236097	Excellent (5)	
15	5/11/2023 20:19:16	Anup Yadav	2246020@sliet.ac.in	2246020	Excellent (5)	
16	5/11/2023 20:23:19	Arafat Ghani Yousuf	2140003@sliet.ac.in	2140003	Very Good (4)	
17	5/11/2023 20:26:22	Vinay Kumar	vinayverma7667@gmail.	2010802	Excellent (5)	No
18	5/11/2023 20:28:45	Raman kumar	2110817@sliet.ac.in	2110817	Good (3)	No
19	5/11/2023 20:31:10	Gaurav kumar	2110723@sliet.ac.in	2110723	Excellent (5)	All was good
20	5/11/2023 20:32:01	Vikas kumar yadav	2140054@sliet.ac.in	2140054	Excellent (5)	
21	5/11/2023 20:37:41	Anya kumari	2236079@sliet.ac.in	2236079	Very Good (4)	Nothing
22	5/11/2023 21:07:16	Nitish kumar	2110922@sliet.ac.in	2110922	Excellent (5)	
23	5/11/2023 21:12:14	Yogesh kumar	2110926@sliet.ac.in	2110926	Very Good (4)	Nooo
24	5/11/2023 21:18:30	Birendra Kumar	2236131@sliet.ac.in	2236131	Very Good (4)	
25	5/11/2023 21:19:59	Shashi Kumar	2140014@sliet.ac.in	2140014	Excellent (5)	
26	5/11/2023 21:23:45	Saransh Sharma	2234105@sliet.ac.in	2234105	Excellent (5)	
27	5/12/2023 0:58:18	Pushkar tiwari	2110703@sliet.ac.in	2110703	Good (3)	
28	5/12/2023 1:05:28	Arjun Kumar	2110710@sliet.ac.in	2110710	Excellent (5)	Nothing
29	5/12/2023 14:54:52	Satyam Suman	2110935@sliet.ac.in	2110935	Excellent (5)	Nothing
30	5/12/2023 15:06:39	Tushar kumar	2110928@sliet.ac.in	2110928	Very Good (4)	
31	5/12/2023 15:19:16	Gaurav Kumar Puri	2110401@sliet.ac.in	2110401	Very Good (4)	
32	5/12/2023 16:29:49	Sonu kumar	2140415@sliet.ac.in	2140415	Excellent (5)	
33	5/12/2023 16:49:38	Raina singh	2110714@sliet.ac.in	2110714	Excellent (5)	
34	5/12/2023 16:50:53	Vanshika	2010067@sliet.ac.in	2010067	Excellent (5)	No
35	5/12/2023 17:20:47	Parkash kumar	2110701@sliet.ac.in	2110701	Excellent (5)	
36	5/12/2023 18:24:53	Aditya Raushan	2110929@sliet.ac.in	2110929	Excellent (5)	
37	5/12/2023 22:38:58	MD AAMIR HUSSAIN	mdaamirhussain721@gn	2010018	Excellent (5)	



# Feedback for day5

	A	B	C	D	E	F	G
1	Timestamp	Name	Email	Registration Number	Feedback for 5th Day A	Suggestions for improvement	
2	5/12/2023 22:10:19	Adarsh Thakur	thakuradarsh926@gmail.	2234120	Very Good (4)		
3	5/12/2023 22:10:34	Parkash kumar	2110701@sliet.ac.in	2110701	Excellent (5)		
4	5/12/2023 22:10:52	Sumit Ranjan Jha	2010671@sliet.ac.in	2010671	Excellent (5)		
5	5/12/2023 22:11:02	Pushkartiwari	2110703@sliet.ac.in	2110703	Excellent (5)		
6	5/12/2023 22:11:09	Raja Kumar	rajaitm2003@gmail.com	2010418	Excellent (5)		
7	5/12/2023 22:11:36	Aman	2140008@sliet.ac.in	2140008	Excellent (5)	Nothing	
8	5/12/2023 22:11:47	Saket kumar	2110912@sliet.ac.in	2110912	Very Good (4)	More people is required for teaching for helping	
9	5/12/2023 22:11:57	Alok Kumar	2110713@sliet.ac.in	2110713	Very Good (4)	All good	
10	5/12/2023 22:11:59	Nitish kumar	2110922@sliet.ac.in	2110922	Excellent (5)		
11	5/12/2023 22:12:01	Pragti chauhan	pragtichauhan458@gmail	2236097	Excellent (5)		
12	5/12/2023 22:12:36	Gaurav kumar	2110723@sliet.ac.in	2110723	Excellent (5)	Session was excellent and knowledgeable	
13	5/12/2023 22:14:06	Shashi Kumar	2140014@sliet.ac.in	2140014	Excellent (5)		
14	5/12/2023 22:15:24	Birendra Kumar	2236131@sliet.ac.in	2236131	Very Good (4)		
15	5/12/2023 22:16:17	Satyam Suman	2110935@sliet.ac.in	2110935	Excellent (5)	Nothing	
16	5/12/2023 22:17:25	Tushar kumar	2110928@sliet.ac.in	2110928	Excellent (5)		
17	5/12/2023 22:18:52	Ayush Raj	2110371@sliet.ac.in	2110371	Excellent (5)		
18	5/12/2023 22:19:11	AYUSH KUMAR THAKUI	2010657@sliet.ac.in	2010657	Excellent (5)		
19	5/12/2023 22:19:12	Vikas kumar yadav	2140054@sliet.ac.in	2140054	Excellent (5)		
20	5/12/2023 22:20:21	Anup Yadav	2246020@sliet.ac.in	2246020	Excellent (5)		
21	5/12/2023 22:20:43	Arjun Kumar	2110710@sliet.ac.in	2110710	Very Good (4)	Nothing	
22	5/12/2023 22:23:40	Chanchal kumar	2110924@sliet.ac.in	2110924	Excellent (5)		
23	5/12/2023 22:23:50	Dikshit kumar	2110921@sliet.ac.in	2110921	Very Good (4)		
24	5/12/2023 22:25:02	Shubham kumar	2236133@sliet.ac.in	2236133	Excellent (5)		
25	5/12/2023 22:28:10	Prasann kumar	prasannkrm2003@gmail.	2010741	Excellent (5)	Everything was best	
26	5/12/2023 22:31:19	Mohammad Nadeem ma	2140382@sliet.ac.in	2140382	Excellent (5)	NA	
27	5/12/2023 22:33:18	Arafat Ghani Yousuf	2140003@sliet.ac.in	2140003	Very Good (4)		
28	5/12/2023 22:37:32	Anya kumari	2236079@sliet.ac.in	2236079	Excellent (5)	Nothing it's really very good session....	
29	5/12/2023 22:37:33	MD AAMIR HUSSAIN	mdaamirhussain721@gn	2010018	Excellent (5)		
30	5/12/2023 22:38:10	RAINA SINGH	2110714@sliet.ac.in	2110714	Excellent (5)		
31	5/12/2023 22:46:37	Vanshika	2010067@sliet.ac.in	2010067	Excellent (5)	No	
32	5/12/2023 22:49:54	Tripti Anand	triptianand1709@gmail.c	2236142	Excellent (5)		
33	5/12/2023 23:14:04	Aditya Raj	araj87314@gmail.com	2110940	Excellent (5)		
34	5/13/2023 1:15:49	Gaurav Kumar Puri	purigaurav2002@gmail.c	2110401	Excellent (5)		
35	5/13/2023 10:58:11	Aditya Raushan	2110929@sliet.ac.in	2110929	Excellent (5)		

# Overall feedback of Training

## How Satisfied are you with the Training

32 responses

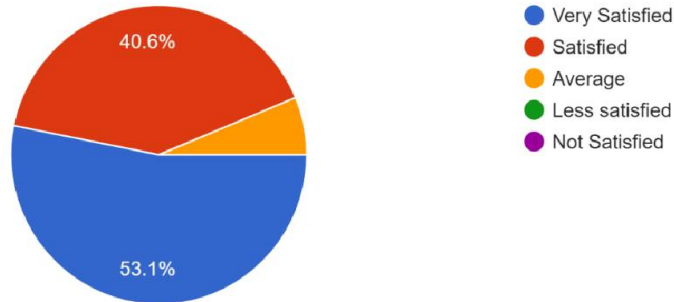

## How helpful was the coordinator's during the Training

32 responses

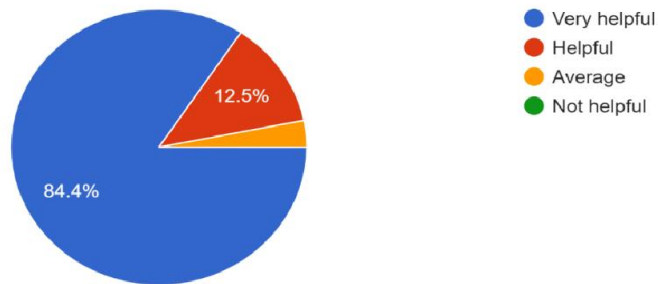

## How much you enhance your Knowledge on AutoCad

32 responses

